



Midea

make yourself at home

CREATING HAPPIER HOME

Vol.16 2022



SMART LIVING

** Visual for reference & illustration purpose only.*

WORLD No. 1

MIDEA PRODUCT LEADERSHIP

FAN

AIR COOLER

PRESSURE COOKER

MICROWAVE OVEN

INDUCTION COOKER

JUG KETTLE

HOME OF THE BEST

world's #1 AIR TREATMENT BRAND

world's #1 SMALL COOKING APPLIANCES BRAND

world's #1 COOLING FANS BRAND

world's #1 AIR COOLERS BRAND

world's #1 RICE COOKERS BRAND

BEST DESIGN AWARD

40
AWARDS OF REDDOT, IF GMARK & IDEA



reddot



design award china

Official Partners of
Mancity and AFF Suzuki Cup



ETIHAD STADIUM



OUR #WORLDCLASS LINE-UP

make yourself at home
with our smart home appliances



OFFICIAL SPONSOR



**AFF
SUZUKI
CUP 2020**



BEST

MICROWAVE OVEN



5 years
WARRANTY MAGNETRON
For all models



Gill
Function
WITH GRILL
FUNCTION



BEST
SELLER



25L

MMO-EG925EXX

- Capacity: 25L
- Membrane Control
- Child safety lock
- 315 mm Turntable Size
- Multi-stage cooking
- Gill Power: 1000W
- Microwave Output Power: 900W
- 11 power levels
- 8 Auto menus
- LED display
- Timer: Max. 99mins 99 secs
- Defrost by time

25L

EM825AGS-BK

- Capacity: 25L
- With Defrost Setting
- LED display
- 270 mm Turntable Size
- Timer: Max. 99mins 99secs
- Microwave Output Power: 750 - 800W
- 11 power levels
- Child Lock Safety features
- 8 Auto Menu Setting
- Multi-stage cooking
- Deforest by time



Indicator Light



Ending Signal



Electronic Control



Deforest by Time



20L

MM720CGE-BK

- Capacity: 20L
- With Defrost Setting
- Push Button Door
- 35-min timer
- Microwave Output Power: 650-700W



20L

MM720CGE-WH

- Capacity: 20L
- With Defrost Setting
- Push Button Door
- 35-min timer
- Microwave Output Power: 650-700W



20L

MM720CXM

- Capacity: 20L
- With Defrost Setting
- Push Button Door
- 35-min timer
- Microwave Output Power: 700W

ELECTRIC OVEN



55L Power **2200W**

MEO-55RCL-BK

- Capacity: 55L
- Mechanical Control Type
- Inner Light



2 years
FULL WARRANTY

For all models

UNIQUE FEATURES



12 Inch Pizza



Up To 230°C High Temperature



120 Mins Timer



Durable Cavity

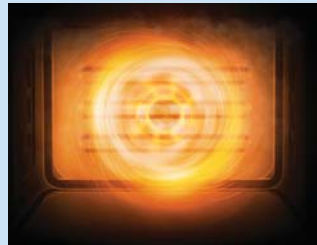

Hot Air Circulation



Rotisseries and Convection



9 Cooking Mode



42L Power **1800W**

MEO-42LGY-BK

- Capacity: 42L
- Metallic tube heating elements
- With rotisseries and convection function
- 60 min timer with bell ring
- 70°C-230°C temperature control
- 5 heating functions
- Square bake tray and wire rack



25L Power **1500W**

MEO-25EX1

- Capacity: 25L
- 6 slices of bread/12" pizza
- 60-min timer with bell ring
- Metallic tube heating elements
- 70°C - 230°C temperature control



10L Power **1000W**

MEO-10BDW-BK

- Capacity: 10L
- 4 slices of bread/9" pizza
- 15-min timer with bell ring
- 2 quartz heating elements
- 2 rack location



10L Power **1000W**

MEO-10BDW-WH

- Capacity: 10L
- 4 slices of bread/9" pizza
- 15-min timer with bell ring
- 2 quartz heating elements
- 2 rack location

RICE COOKER

DIGITAL RICE COOKER



1300W IH 3D Heating Heats



Larger Heating Area Heats More Evenly



Cast iron produces higher heat than aluminum



Fine Iron Liner Energy-concentrating



Micro-pressure Boiling Persistent Boiling without Overflow



Micro-pressure Afterheat Braising Provides Nutrition and Sweetness

1.8L

MB-18HS

- Capacity: 1.8L
- IH 3D Heating
- T1.5mm inner pot with non-stick coating
- Plane Frosted Panel
- Elegant Gold Color
- Streamline Design
- Power: 1300W



3D Heating Heats



Removable Inner Lid

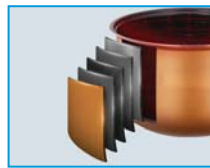

5 Layers Non-Stick Inner Pot



Turbo steamer for better cooking

1.8L

T3.0mm Inner Pot

Removable Inner Lid

MB-D1809GL

- Capacity: 1.8L
- Easy-to-read LED Digital
- High quality metal housing
- T3.0mm inner pot with non-stick coating
- Multi-function cooking by menu settings
- 24 hours preset timer
- Automatic keep warm function
- 12hr keep warm function
- Touch control panel
- Power: 760W



1.8L

T1.5mm Inner Pot

Removable Inner Lid

MB-FS17

- Capacity: 1.8L
- Easy to read LED Digital
- Removable inner lid
- 24 hours preset timer
- LED Digital
- Touch button on the panel
- Multi function cooking by menu setting
- T1.5mm inner pot with non-stick coating
- Power: 770-918W
- Voltage: 220-240V

MINI JAR RICE COOKER



0.8L

T1.7mm Inner Pot

MB-070B

- Capacity: 0.8L
- T1.7mm Inner Pot with non-stick coating
- One touch open for safe usage
- Keep your food warm, easy for baby food
- To release pressure steam while cooking
- Power: 416W



MR-CM06SB



MR-CM06SC

0.6L

T1.0mm Inner Pot

- Capacity: 0.6L
- T1.0mm Inner pot with non-stick coating
- Cook and keep warm function
- Power: 400W

RICE COOKER

JAR RICE COOKER



MR-SM1861-GN **NEW**

1.8L **T1.7mm**
Inner Pot

- Capacity: 1.8L
- Ready to cook Light
- Keep Warm
- Auto Swtich Off
- Power: 700W



MR-SM1861-RD **NEW**

1.8L **T1.7mm**
Inner Pot

- Heating Up Light
- Golden non-stick coating
- Detachable Cord
- Large steam vent



Golden non-stick coating



Easy to clean



Inner pan handle



Steam vent set removable to clean



2.2L **T1.0mm**
Inner Pot

MR-CM2224 **NEW**

- Capacity: 2.2L
- T1.0mm inner pot with aluminum alloy
- Glass lid
- Power: 900W



1.5L **T1.0mm**
Inner Pot

MR-CM1521

- Capacity: 1.5L
- T1.0mm inner pot with non-stick coating
- Multi-function for cooking
- Automatic keep warm function
- Power: 700W



1L **T1.0mm**
Inner Pot **Detachable Inner Lid**

MB-10YJ

- Capacity: 1L
- Power: 500W
- T1.0mm inner pot with non-stick coating
- Removable large steam vent
- Detachable inner lid for easy cleaning.



1.8L **T1.0mm**
Inner Pot **Detachable Inner Lid**

MB-18YJ

- Capacity: 1.8L
- Power: 650W
- T1.0mm inner pot with non-stick coating
- Removable large steam vent
- Detachable inner lid for easy cleaning.



1.8L **T1.0mm**
Inner Pot

MB-18YH

- Capacity: 1.8L
- T1.0mm inner pot with non-stick coating
- Removable large steam vent
- Power: 650-773W

CONVENTIONAL RICE COOKER



1L **T1.0mm**
Inner Pot

MR-GM10SDA-B

- Capacity: 1L
- Power: 500W
- T1.0mm aluminium inner pot
- Stainless Steel lid



1.8L **T1.0mm**
Inner Pot

MR-GM18SDA-B

- Capacity: 1.8L
- Power: 700W
- T1.0mm aluminium inner pot
- Stainless Steel lid

1L **T1.0mm**
Inner Pot

MR-GM10SDA-R

- Capacity: 1L
- Power: 500W
- T1.0mm aluminium inner pot
- Stainless Steel lid

1.8L **T1.0mm**
Inner Pot

MR-GM18SDA-R

- Capacity: 1.8L
- Power: 700W
- T1.0mm aluminium inner pot
- Stainless Steel lid



0.6L **T1.0mm**
Inner Pot

MG-GP06B

- Capacity: 0.6L
- T1.0mm aluminium inner pot
- Glass lid
- Power: 350-417W



1.3L **T1.0mm**
Inner Pot

MG-GP10B

- Capacity: 1.3L
- Automatic keep warm function
- Cooking indicator light
- Durable alloy-aluminium inner pot

- Non-stick coating
- Clear tempered glass lid
- Inner plastic steamer
- Power: 450-550W



1.8L **T1.0mm**
Inner Pot

MG-GP18B

- Capacity: 1.8L
- T1.0mm aluminium inner pot
- Stainless Steel lid
- Power: 700-833W

AIR FRYER CUM PRESSURE COOKER

DUAL LID

Air Fryer cum Pressure Cooker



5.7L

MY-CN65A

NEW

- 2 in 1 Multi-Cooker
- 1500W strong power for fast cooking and saving your time
- 15 menu functions in 1 multi-cooker makes you easy to cook the perfect food (Stew, Air fry, Sous Vide, Slow cook, etc)
- Removable pressure lid for easy cleaning and storage
- 12hrs delay and warm-keeping function
- 5.7L big capacity for enjoying together
- Big panel with easy operation, easy use for all generation

UNIQUE FEATURES

AIR FRYER



Air fryer cover



Heating system for best performance. Storm shape design heating element. 1500w big power fast heating.



Stereoscopic air duct design for even heating. Multi-angle hot air convection heating, fast heat and crisp food.



Convenient handling makes it easy to move with 6.5 liter big capacity satisfying most needs



Hollowed design fry basket for fast and even cooking

PRESSURE COOKER



Pressure cooker cover

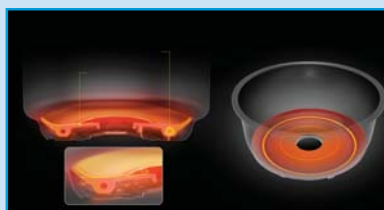

New heating element for fast heating and cooking



PRESSURE COOKER



MULTI FUNCTION COOKING 8-in-1 multiple uses



Rice Cooker



Sauté



Warmer



Soup Maker



Pressure Cooker



Yogurt



Steamer



Slow Cooker

5.7L T1.5mm Durable Aluminium inner pot

MY-D6004B

- Capacity: 5.7L
- Multi-function: 8-in-1 cooker
- 15 pre-programmed menu for versatility
- Customized DIY functions
- Sauté with open pot
- T1.5mm durable aluminum inner pot
- Stainless steel exterior
- Easy to use with large LCD control panel
- 24-hour preset timer
- 9-proven safety mechanism for worry-free use
- Power: 1000W

DUAL INNER POT



5.7L T1.7mm Durable Aluminium inner pot

MY-D6007SS2

- Capacity: 5.7L
- Dual pots T1.7mm two side painting Aluminum & Stainless Steel inner pot
- Large control box and 4-Digit LED display
- Pressure indicator showing the pressure status
- Multi-function, 15 preset menu
- 24 hours preset timer
- When the lid is not properly secured, function keys will be blocked by a failsafe switch
- 9 safety guard
- Working pressure 70KPa
- Stainless steel housing
- Power: 1000W

5L T1.8mm non-stick Inner Pot

MY-CH502A

- Capacity: 5L
- Dual inner pot
- Easy to use pre-set mechanical dial with max. 45 min timer
- Pressure indicator showing the pressure status
- Working pressure 30-70KPa
- 7 Menu Preset
- Power Off memory function
- 10 safety features
- Power: 900W

INDUCTION COOKER



FREE Pot for all induction cooker



UNIQUE FEATURES



188mm large heating area



8 cooking programs



24 hours preset



Power
2000W

C20-RT2002

- 188mm large heating area
- Professional uniform IH technology for even heating
- Leading constant heating ensure better cooking performance
- Integral glass panel & touch control

- 40mm slim design
- 10-stage power setting
- 8 cooking programs
- 24 hours preset
- 3 hours timer



Power
1600W

C16-RTY1619-BK

- Knob control
- 8 stage power settings
- Automatic safety shut-off switch



Power
1600W

C16-RTY1619-GL

- High temperature protection
- Available colour: Black & Gold
- Power: 1600W



AIR FRYER



5.5L Power **1700W**

MAF-D55A **NEW**

- Capacity: 5.5L
- Touch mode intelligent operation
- Suitable for Baking, Roasting, Frying and Grilling
- Removable frying basket, can cook different food without it.
- Safety Protection comes with auto-shut off, fry pot returns will continue cook
- Power: 1700W

UNIQUE FEATURES

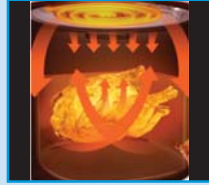

3D Rapid Air Circulation



Turbine vortex heating tube, longer service life



Easy Load Basket with Non-Stick Coating



Convenient and quick to take out the bucket and push it in



Intelligent touch panel



Surrounding the 3D wind guide groove and one-button light-spinning separation basket and drip barrel



3.5L Power **1500W**

MAF-D3500 **NEW**

- Capacity: 3.5L
- 3.5QT big capacity for enjoying together.
- Timer with automatic shut-off
- Adjustable temperature up to 200 °C
- Frying basket with rapid hot air circulation system
- Preset programs make cooking easy and professional
- 1500W strong power for fast cooking and saving your time

UNIQUE FEATURES



3D Rapid Air Circulation



Multi-function for Versatility



Customized Temperature and Timer



Easy Load Basket with Non-Stick Coating



Effortless Care with Oil Free Air Fryer



3.5L Power **1400W**

MAF-35A

- Capacity: 3.5L
- 60 minute timer setting
- Stay Cool Exterior
- Easy Knob Design
- Functional Capability of Baking, Roasting, Frying and Grilling
- Frying basket with separator cook with different food
- Safety Protection with Automatic Shut Off, Cooking will continue when the fry pot returns
- Power: 1400W

MIXER

STAND MIXER



Power
600W
MSM-400BL **NEW**

- ABS Plastic housing
- 4L SUS bowl for CE version
- Electronic speed control with 6 speeds
- Head lift interlock
- Standard accessory : dough hook/beater/whisk



Power
400W
SM0293-BK

- Tilting head lift
- 5 speed with turbo button
- One touch beater ejector
- One set SUS 304 Stainless Steel beater



Power
400W
SM0293-R

- Accessories: Detachable base, mixing bowl, dough hook, whisk
- Available Colour: Black & Red

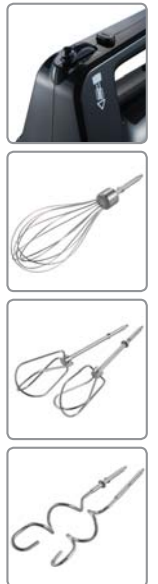

HAND MIXER



Power
300W
HM0273

- 6 speed with turbo button
- Cord wrap storage
- Special bowl rest to prevent dripping
- One set SUS 304 Stainless Steel beater
- Accessories: SUS 304 hooks, whisk and storage

CHOPPER



Power **200W** Capacity **0.6L**

MBC-06PK

- Capacity: 0.6L
- Detachable usable 0.6L Glass bowl
- ON/OFF press button
- 3 leaves SUS chopping blade
- Plastic injection color body
- AC Motor

BLENDER



Power **500W** Plastic Jar **1.5L** Measuring Cup **50ml**

MBL-3502

- Capacity: 1.5L Plastic jar
- 50ml measuring cup
- 6 speeds with Pulse function
- 4 slices of stainless steel blade



Power **750W** Glass Jar **1.5L** Grinder Cup **0.4L**

MBL-1190

- Capacity: 1.5L glass jar
- 60ml measuring cup
- 2 speeds with pulse function
- Ice crush function
- Interlock protection
- Detachable blade for easy cleaning
- Portable handle design
- Dishwasher safe



Power **350W** Plastic Jar **1.25L** Grinder Cup **0.2L**

MBL-35BK

- Capacity: 1.25L Plastic Jar
0.2L Grinder Cup
- 2 speed control
- Pulse switch control
- Stainless Steel blade
- Base security lock



Power **250W** Plastic Jar **1.2L** Grinder Cup **0.4L**

- Capacity: 1.2L Plastic Jar
0.4L Grinder Cup
- Non-slip rubber feet
- Base security lock
- ON/OFF rocker switch control
- Stainless steel blade



MBL-25GN



All Blender with **4 blades**
Stainless steel blade

ELECTRIC KETTLE

COOL TOUCH JUG KETTLE



1.7L Power **2150W**

MK-17PJ

- Capacity: 1.7L
- 304 Stainless Steel inner wall
- Durable thermostat for longer use
- Double wall for anti-scald protection
- Pop-up Lid
- Auto switch off for Boil-Dry protection
- 360° rotating base

COOL TOUCH Double wall for anti-scald protection



Coloured metal body

Stainless Steel Vessel



1.5L Power **2150W**

MK-15HJ

- Capacity: 1.5L
- 304 Stainless Steel inner wall
- Durable thermostat for longer use
- Double wall for anti-scald protection
- Pop-up Lid
- Auto switch off for Boil-Dry protection
- 360° rotating base



1.5L Power **2200W**

MK-15HJ

- Capacity: 1.5L
- 304 Stainless Steel inner wall
- Durable thermostat for longer use
- Double wall for anti-scald protection
- Pop-up Lid
- Auto switch off for Boil-Dry protection
- 360° rotating base



1.5L Power **2150W**

MK-15D

- Capacity: 1.5L
- Double wall for anti-scald protection
- Durable thermostat for longer use
- Fast boiling to save time
- Pop-up Lid
- Auto switch off for Boil-Dry protection
- 360° rotating base



1.7L Power **2150W**

MK-1701

- Capacity: 1.7L
- Stainless Steel inner wall
- Double wall for anti-scald protection
- Durable thermostat for longer use
- Pop-up Lid
- Spout cover
- Neon power indicator
- 360° rotating base

ELECTRIC JUG KETTLE



1.7L Power **2200W**

MK-17GO2

- Capacity: 1.7L
- Spout filter
- LED Light for boiling indication
- Conceal Stainless Steel heating element
- One touch Pop-up lid
- Blue illumination light when boiling
- 360° power base for easy use
- Cord storage for no messing
- With high quality glass body



1.7L Power **2200W**

MK-17S31B

NEW

- Capacity: 1.7L
- Pop-up Lid
- Auto switch off for Boil-Dry
- 360 degree rotating base
- Stainless Steel



1.7L Power **2200W**

MK-17S33D

NEW

- Capacity: 1.7L
- Pop-up Lid
- Auto switch off for Boil-Dry
- 360 degree rotating base
- Stainless Steel

THERMO POT



5L Power **630-750W**

MTP-7055T

- Capacity: 5L
- Expansion technology inner pot get large capacity
- 4 Safety designs with extra protection
- Stainless steel inner pot for safe use

AIR PURIFIER

UNIQUE FEATURES

- CADR: 380m³/h
- 33b(A) Silent Mode
- Removes Bacterial

CADR 380m³/h

MAP-28BD

- Speedy Purification
- Compact Design
- 5 Layers Of Filter Purification
- Removes Aldehyde
- Removes Bacterial
- Auto Cleaning
- 33B(A) Silent Mode
- Auto Screen Off During Night Mode
- PM2.5 Pure Air
- CADR: 380m³/h
- Power Supply: 220-240V-, 50Hz, 1Ph
- Power Consumption: 50W

5-layer filter: Pre-filter + activated carbon HEPA

Pre-filter
Removes hair/dust and large pollutants

Anti-bacteria PET layer
Removes large particles and protect the HEPA filter

Activated carbon layer
Absorbs odors and formaldehyde, VOC and other decoration pollution

HEPA filter
Removes up to 99% allergens & germs as small as 0.3mm

Nylon mesh filter
Protects the HEPA filter

Applicable for EU-KJ700G-H32, KJ500G-TB32, KJ550GJA32, KJ350G-S1

Powerful Purification with 360° all-round purification
The 360° clean air system promotes air into all sides to maximize efficiency and deliver purified air faster. Enjoy your personal clean air around you.

CADR 118CFM 200m³/h

MAP-20BD

- CADR: 118CFM, 200m³/h
- Power Supply: 220-240V-, 50Hz, 1Ph
- Power Consumption: 50W
- Refreshing Ionizer
- Powerful CADR
- Sensuous Sleep Mode
- 1/2/4/8hr Timer

UNIQUE FEATURES

4-stage Filtration System

- 1 Pre-Filter
- 2 HEPA Filter
- 3 Active Carbon Filter
- 4 Ionizer

VACUUM CLEANER

STEAM MOP CLEANER



Power
1400W

Water Tank
0.42L±0.05

MVC-SC20B **NEW**

- Cord length 5m
- Water tank capacity: 0.42L±0.05
- Heating time: 15s
- Running time: 15-22min

UNIQUE FEATURES



130°C Steam

Kill 99.9% bacteria without chemical residue



15S Quick Release Of Steam



Easy To Use And Maneuver



Detachable Water Tank

Convenient to fill in or pour out water



Naturally clean both on and above floors with useful tools

VACUUM CLEANER

CORDLESS STICK VACUUM CLEANER



Power
100W

MVC-3315PP

NEW

- 2 in 1 cordless design
- Running time: 15-22 mins
- Suction Kpa: ≥ 4.2 kpa
- Single-cyclone
- Compact design
- Light weight and user friendly
- Stick and Handheld 2 in 1 design
- Swivel head for easy maneuverability

Power
150W
DC motor

MVC-V18P

- 2 in 1 cordless handstick, Your Versatile Cleaning Expert
- Running time: 25-45 mins
- Suction Kpa: ≥ 7 Kpa
- Easy to use and empty
- High efficiency motor offers powerful suction
- Ergonomic handle for comfortable carrying and convenience to easily access hard to reach areas

Power
350W
BLDC motor

MVC-V18PR

- 2 in 1 cordless handstick, Your Versatile Cleaning Expert
- Running time: 18-45 mins
- Suction Kpa: ≥ 12 Kpa
- Easy to use and empty
- High efficiency motor offers powerful suction
- Ergonomic handle for comfortable carrying and convenience to easily access hard to reach areas

VACUUM CLEANER

HAND-HELD & STICK VACUUM CLEANER



Power
450W

MVC-16P-BG

- Color: Black Gold
- Dust Capacity: 0.4L

Power
450W

MVC-16P-BA

- Color: Beige Apricot
- Dust Capacity: 0.4L

UNIQUE FEATURES

Hand-Held & Stick, 2 Options Your Versatile Cleaning Expert

Stick / hand-hels two-in-one design, one machine dual-use with free switch can easy clean the ground, home surfaces, gaps and narrow spaces



Ergonomic handle
Not easy to slip off



Long tube
Light material, strong and durable



Tight link of clasp
Easy switch



Low noise
Noise Down To 78dB(A)



Hand-Held And Stick 2in1 Design



Straight Air Duct Design



450W Motor With Big Suction Power



Single-Cyclone Filtration System



Quadruple Filter



Different Brush For Multi-Use



Power
600W

MVC-SC861R

MVC-SC861B

- 2-in-1 design
- Transparent dust cup
- Light and user-friendly design



Power
600W

MVC-16T-GN

MVC-16T-B

- HEPA Filter
- 2 in 1 design
- Light Weight
- Available colour: Green & Blue



VACUUM CLEANER

BAGLESS VACUUM CLEANER



Power
1800W
MVC-V18K-BG

• Color: Black Gold



Power
1800W
MVC-V18K-BA

• Color: Beige Apricot

UNIQUE FEATURES



Lightweight Design



No Loss of Suction



HEPA Filtration



Washable Filters



Quick Dust Release



One-touch Automatic Rewind



Powerful Suction
Uniquely designed motor creates powerful suction and high performance cleaning.



16-Foot Long Power Cord

Save the time of unplugging with a long cord that can reach throughout your home.

- Dust Capacity: 1.5L
- Cord Length: 5m



Power
1000W
MVC-V12K-GR

- Dust Capacity: 1.5L
- Suction Power: 130W

- Eco version available
- Ergonomic handle for easy carrying



Easy Dust Disposal
Push button to empty dust cup



Light Weight & Compact Design



Automatic rewind



Main Brush For Both Floor And Carpet



HEPA Filter Removes dust particles from air



Small 2 in 1 Brush

VACUUM CLEANER

VACUUM CLEANER COMES WITH BAG



Power 1400W
MVC-C1433-BG

Power 1400W
MVC-C1433-BA

• Color: Black Gold

• Color: Beige Apricot

- Dust Capacity: 1.5L
- Cord Length: 5m

UNIQUE FEATURES



Tackle the Sticky Dust
Deep removal of dirt with strong suction.



Extended Reach
6.5 Meters of total reach with 5m cord and 1.5m hose.



Floor Brush with 360-degree Angle
Different angles realize the convenient direction turning for various cleaning needs.



Weight Less Than 2.6kg



Vacuum Cleaner comes with Dust Bag



One-touch Automatic Rewind



Compact Design for Easy Storage



Power 1200W
MVC-C1211S-BL

Power 1200W
MVC-C1211S-RD



Main Brush MB02



Small 2 in 1 Brush



Strong Suction Power



HEPA Filter



Dust Full Indicator



Light Weight

- Washable Micro dust bag
- Dust full indicator
- Ergonomic handle for easy handling
- High efficiency motor
- Exhaust HEPA filter
- 2 PC plastic tube
- Suction power: 180W

WATER PURIFIER

Activate Your Healthy Water with a Simple Switch

Portable Faucet Water Purifier



MC122-2

- Multiple Use
- Compact Body
- Disposable Filter
- ABS Plastic Body
- 2L/min Purified Water Flow
- Rate Total Purified Water: 1200L
- Work Pressure: 0.1 - 0.4MPa

1 years
WARRANTY

UNIQUE FEATURES

Double Outlet

Customize Your Water with a Simple Switch
Simply push the button for the instant filtered water.



DIY Installation

Upgrade Your Faucet in a Few Simple Steps
No after service and tools are needed to finish an easy installation process.



Zero-waste Technology

Improved Taste, Reduced Waste

Our Zero-waste Technology equipped with carbon fiber filter helps to improve the taste of water and remove 96% waste chlorine from tap water.



Non-electric Filtration
No Electricity Cost Needed

4-level Water Filtration

Maximum 96% Chlorine Absorption Capacity

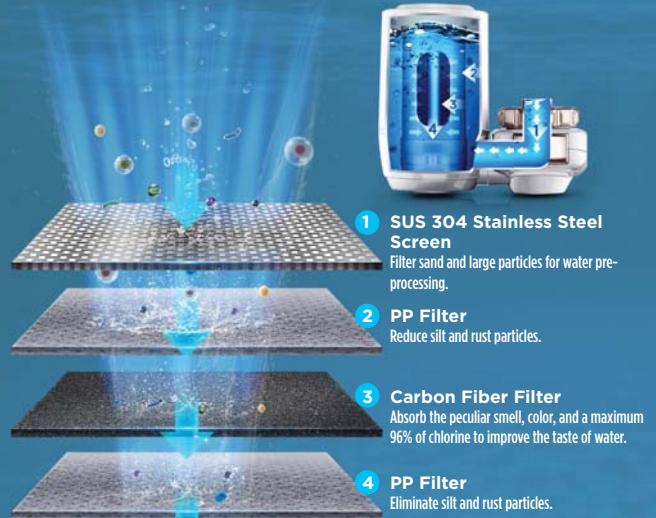

2L/min Fast Water Flow

Quickly Preparing Clean Vegetables and Fruits for Healthy Cooking



WATER DISPENSER



YD1518S-X

- The newest slim design
- Advanced semi-conductor cooling
- Heated water temperature $\geq 85^{\circ}\text{C}$
- Chilled water temperature $\leq 15^{\circ}\text{C}$
- 1.02L hot tank capacity
- 1 year warranty

UNIQUE FEATURES



Automatic Heat Preservation System
Constant Hot Water is Always Ready to Drink



Integrated Water System
Reduce water residue and leakage



Convenient Control Knobs
Easily Access to Your Drink with No Pressing



Removable Drip Tray
Easy to clean. Also, a reliable helper to manage overflow.



36L Large Storage Space
A place to store everything



Support Bar
Increase anti-topping stability



Durable Food Contact Grade Parts
• SUS304 Stainless Steel Hot Tank anti-topping stability
• Water Diversion Tank



Removable Bottle Supporter
Scale Deposit is Cleaned Easily



Double Door with Tempered Glass
Separate the dust outside and cleanliness inside.

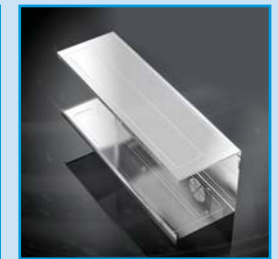

One-piece Stretched Sheet Metal
Seamless Look is Built to Last

- Double safety device for preventing overheat
- High power stainless steel hot water tank
- Heated water capacity min at 25°C
- Chilled water capacity min at 25°C
- 0.6L cold tank capacity
- Power: 420W heating/75W cooling



YR-1539T

- New design
- Exclusive safety device for preventing overheat
- High quality stainless steel tank for hot water
- Heated water temperature $\geq 85^{\circ}\text{C}$

UNIQUE FEATURES



Removable Bottle Supporter
Scale Deposit is Cleaned Easily



Advanced Semi-Conductor Cooling



Compact Size



Detachable Drip Tray



The Loading Qty Can Reach 1600Pcs



- Heated water capacity min at 25°C
- Room temperature water
- Power: 420W heating

**Water bottle is not included*

FAN

STAND FAN



3 in 1 Function: stand fan and living fan



Remote Control



5 ABS Fan Blade

MF-16FS18BR

- Size: 16"
- High quality copper motor
- Longer air flow distance
- Oscillation function
- Sleep Mode
- 8 speed levels
- Remote control
- Adjustable fan head angle
- 3 in 1 function
- 8 hours timer
- 5 ABS fan blade
- With remote control
- Power: 60W



2 in 1 Function: stand fan and living fan



Compact Designed
Speed Control

Size
16in

- Size: 16"
- 3 ABS fan blade
- Power: 50W
- 3-speed
- Available Colour: Black & White

MF-16FS18C-WT

MF-16FS18C-BK



Size
16in **5**
Blade

MF-16FS15F

- Size: 16"
- 3-speed & 2 hours timer
- 5 ABS fan blade
- Available Colour: Black
- Power: 50W



Size
16in

MF-16FS10N

- Size: 16"
- 3-speed choices
- 3 ABS fan blade
- Power: 55W



Size
16in

MF-16FS10NS

- Size: 16"
- 3-speed choices
- 3 ABS fan blade
- Power: 55W

FAN

CEILING FAN



Size **60in**
MFC-150A15

3 years
WARRANTY MOTOR

- Size: 60"
- Plastic cover, wider sweeping blades
- Double safety mechanism
- Long-lasting motor
- Power: 75W
- 5-speed choices



Size **56in**
FC140-CJR



5 ABS
Fan Blade



3 Speed Fan



Remote Control

- Size 1400mm (56")
- High: 4300mm (17")
- 6-hours Time Settings
- Power: 65W

3 years
WARRANTY MOTOR

TABLE FAN



Size **12in**
MF-12FT17NB

- Size: 12"
- Power: 45W

- 3-speed choices
- Both tilting angle & oscillation available
- Available Colour: Blue



Size **16in**
MF-16FT17NB

- Size: 16"
- Power: 55W



Size **16in**
MF-16FT15NB

- Size: 16"
- 3-speed choices
- Both tilting angle & oscillation available
- Available Colour: Blue
- Power: 55W



Size **12in** **COMPACT DESIGN**
MF-12FT16JC

- Size: 12"
- 3-speed choices
- Both tilting angle & oscillation available
- Available Colour: Black
- Power: 45W

WALL FAN



Size **16in**
MF-16FW15KRA

- Size: 16"
- 3-speed choices & 7.5 hours timer
- Both tilting angle & oscillation available
- With Remote Control
- Power: 55W



Size **16in**
MF-16FW15KA

- Size: 16"
- 3-speed choices
- Both tilting angle & oscillation available
- Double line pull switch
- Power: 55W



Size **16in**
MF-16FW6H

- Size: 16"
- 3-speed choices
- Both tilting angle & oscillation available
- Double line pull switch
- Available Colour: Grey
- Power: 50W

FAN

TOWER FAN

GENTLE COOLING WIND

Stay comfort with gentle airflow surrounded



MTF-101K

- New air duct design
- High quality copper motor
- Oscillation function
- 3 speed levels
- 3 hour timer
- Power: 45W



New Air Duct Design



Powerful Motor



3 Speeds



3hrs Timer



Oscillation Function



Knob Control

UNIQUE FEATURES

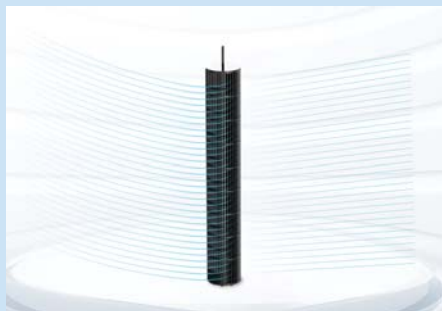

New Air Duct Design

Unique design of the air duct that minimizes the volume down to 52db*
(*Tested in Midea Lab)

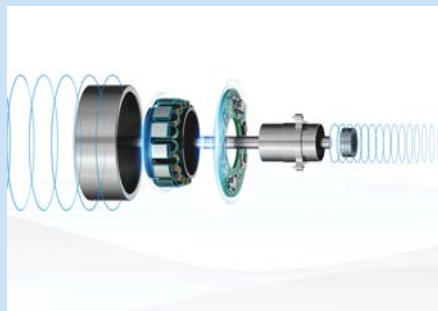

High Quality Copper Motor

The copper motor is stable to operate with long life span



Oscillation Function

Deliver 85° wide range cooling for more comfort space coverage

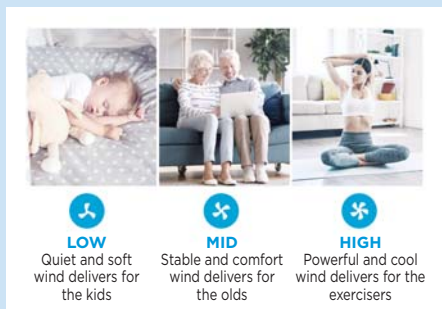

LOW
Quiet and soft wind delivers for the kids



MID
Stable and comfort wind delivers for the olds



HIGH
Powerful and cool wind delivers for the exercisers

3 Speed Levels

Multiple speed control to reach the various usages



3 Hours Timer

Custom your desired operation timing for your comfort within 3h



Knob Control

AIR COOLER

UNIQUE FEATURES



7L
Water Tank
MAC-107AR



Waterless Protection
And Alarm



Compact Design
Space Save 40%



Convenient To Clean



7L Water Tank

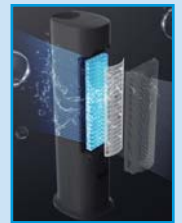

Purifying Filter At The
Back

- Capacity: 7L
- 3 speed levels for various usage
- Humid function deliver cooler wind
- 7 hours timer setting

- 10 Hour programmed timer
- LED display
- Remote Control
- Power: 65W

UNIQUE FEATURES



Power Off
Memory



Wide Angle
Oscillation



Air Purifying
Effect



Humidifier



Auto Shut-off pump
protection when dry



7-hours Time
Settings



3 Speed Fan



Remote
Control



Multi-functional
Fan



Ionizer
(only for model MAC-215F)



10L
Water Tank
MAC-120AR

- Capacity: 10L
- Power: 60W



6L
Water Tank
MAC-106A-BK

- Capacity: 6L
- Power: 55W



15L
Water Tank
MAC-215F

- Capacity: 15 L
- Power: 60W



With Aroma Box



Frozen water bottle can
be place into inlet holes
to add in more cold
water and bring out
cooler & fresher air

* This feature only applicable for MAC-215F
and recommended bottle size is 1.5L

GARMENT STEAMER

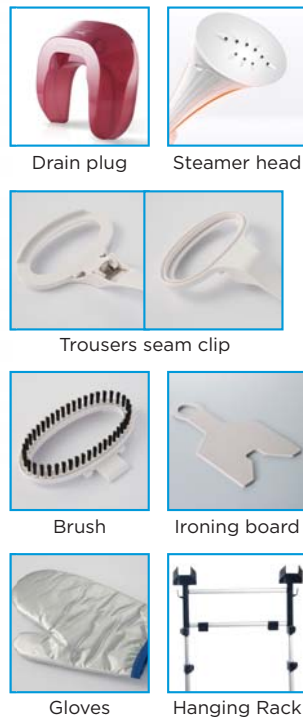

Power
1500-1785W

GS-120D

- 3 Level mechanical control
- 35g/min continuous steam
- 2 Liter Removable water tank
- Fast Heat up, ready for use in 40 second
- Silence & high efficiency power heater
- Dual temperature protection
- 9 holes & big size steam head
- Multiple anti-bend steam tube
- Adjustable integrated dual studdle



Power
1500-1785W

GS-150D

- 1.5 Liter Removable water tank
- 3 level steaming
- Fast heat up in 60 seconds
- Dual temperature protection
- 9 holes and big size steam head
- Multiple anti-bend steam tube



Midea Scott & English Electronics Sdn Bhd (194517-X)

No. 16, Jalan Chan Sow Lin, 55200 Kuala Lumpur Tel: 03-9221 1033 Fax: 03-9221 7204 / 03-9221 1434 / 03-9221 3509

PENANG

No. 35, Jalan Perniagaan Gemilang 1,
Pusat Perniagaan Gemilang,
14000 Bukit Mertajam, Pulau Pinang.
Tel: 04-548 3938 Fax: 04-548 9698

JOHOR

No. 25, Jalan Seri Impian 1,
Taman Impian Emas,
81300 Skudai, Johor.
Tel: 07-562 4898 Fax: 07-557 7898

PERAK

No. 38, Persiaran Perindustrian Pengkalan 10,
Kawasan Perindustrian Pengkalan,
31500 Lahat, Perak.
Tel: 05-323 2529 Fax: 05-323 2529

PAHANG

No. 258, Ground Floor, Jalan Air Putih,
Taman Air Putih Mewah,
25350 Kuantan, Pahang Darul Makmur.
Tel: 09-560 6668 Fax: 09-09-560 5050

MALACCA

No. 385-L, Taman Peringgit Jaya,
75400 Peringgit, Melaka.
Tel: 06-292 1940 Fax: 06-286 7107

KOTA BHARU

PT 1436, Ground Floor,
Taman Koperatif, Tanjung Chat,
15300 Kota Bharu, Kelantan.
Tel/Fax: 09-743 1202

SABAH

Inanam Suria Commercial Centre,
Lot B, Unit 0-9, Unit 1-9,
Ground Floor and First Floor,
88450, Kota Kinabalu, Sabah.
Tel: 088-421 428 Fax: 088-431 427

SARAWAK

1st Floor, Lot 8517,
Stutong Commercial Centre, Jalan Stutong,
93350 Kuching, Sarawak.
Tel: 082-363 167 Fax: 082-366 167

Dealer's Stamp:

Available at lazada & Shopee



shopee.com.my/midea.os



Lazada

[lazada.com.my/shop/
midea-official-store](https://lazada.com.my/shop/midea-official-store)



[midea_malaysia](https://www.instagram.com/midea_malaysia)



[Midea Malaysia](https://www.facebook.com/MideaMalaysia)



my.midea.com