



Midea

*make yourself at home*

## CREATING JOYLOUS HOME

Vol.1 2022



KITCHEN & WATER APPLIANCES

\* Visual for reference & illustration purpose only.

# COOKER HOOD

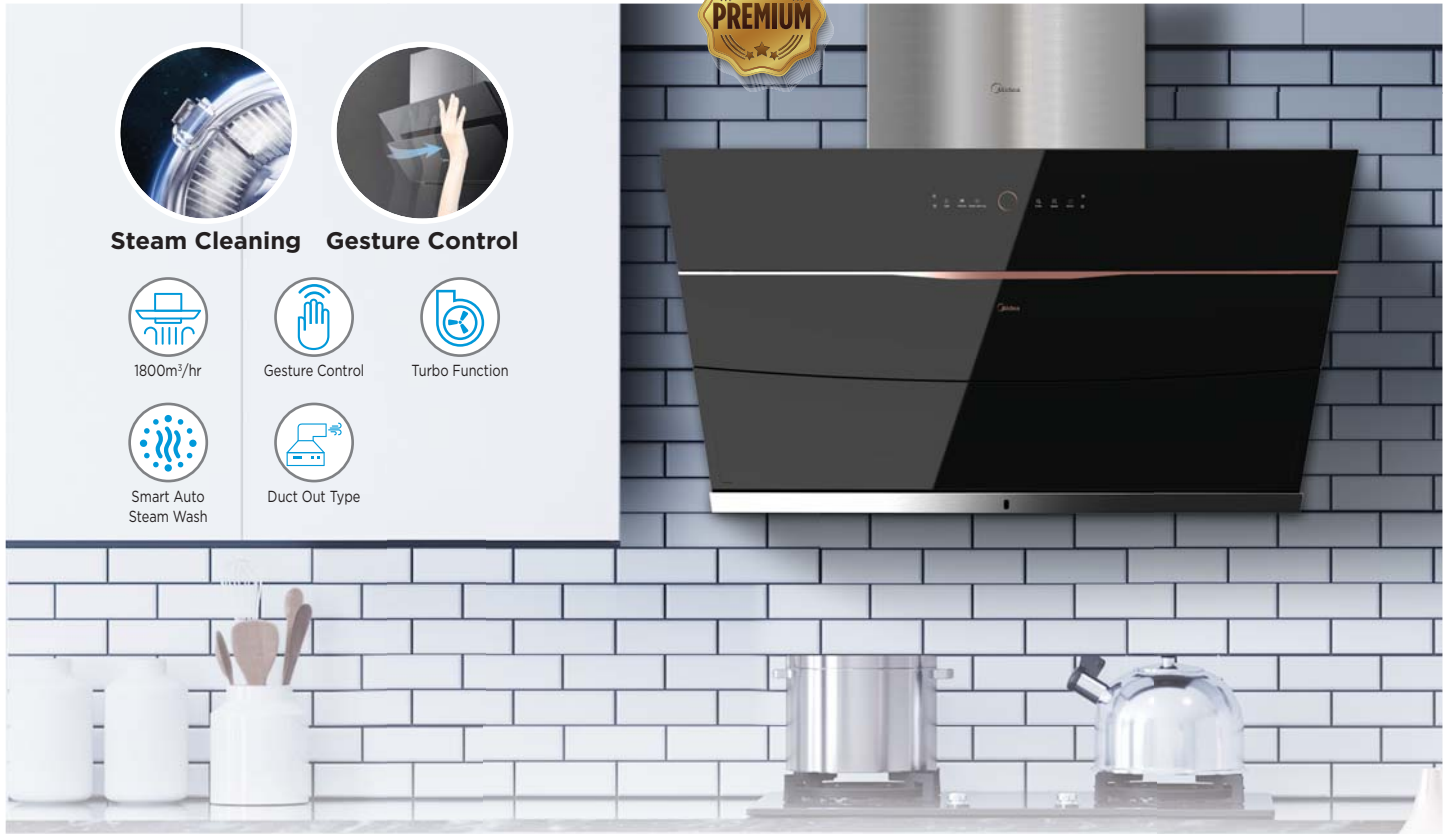

## Steam Cleaning Gesture Control



1800m<sup>3</sup>/hr



Gesture Control



Turbo Function



Smart Auto Steam Wash



Duct Out Type

Suction Power  
**1800m<sup>3</sup>/hr**

Duct Out  
Only

## MCH-90B68AT

- Auto Steam Wash Cleaning Technology
- Suction power: 1800m<sup>3</sup>/hr
- Touch control
- Gesture control (Hand wave power On/Off)
- LED lamp: 2 x 1.5W
- Duct out operation mode

- Easy clean elongated oil cup
- 2 speeds selection with Turbo speed function
- Included aluminium ducting hose
- Ducting hole dimension 180mm
- Product dimension (mm): 895(W) x 416(D) x 505(H)

**5** YEARS WARRANTY  
**MOTOR**

## UNIQUE FEATURES



### Sustain Excellent Suction Performance with Self-cleaning Steam Wash



### Self-Cleaning Steam Wash

A perfect solution for hood interior cleaning, maintaining the appliance always with a decent performance and longer serving-you time.



### Hand Wave Control

A convenient alternative to suspend or stop your hood when inconvenient to touch the screen.



### 1800m<sup>3</sup>/h Strong Suction

Powerful airflow to efficiently remove the most unpleasant odors, steam and grease.



### Complete Smoke Removal

The duct out type exhausts cooking fumes outside the house thoroughly and keeps your kitchen air fresh indeed.



### 3-Minutes Super Extraction Power

Our turbo function can provide 3-minutes maximum suction (1800m<sup>3</sup>/h), perfectly suitable for stir frying.

# COOKER HOOD



**Gesture Control**



1800m<sup>3</sup>/hr



3D Ventilation



Turbo Function



Gesture Control



Duct Out Type



Suction Power  
**1800m<sup>3</sup>/hr**

Duct Out  
Only

## MCH-90B65

- Suction power: 1800m<sup>3</sup>/hr
- Touch control
- Gesture control (Hand wave power On/Off)
- LED lamp: 2 x 1.5W
- Duct out operation mode

- Easy clean elongated oil cup
- 2 speeds selection with Turbo speed function
- Included aluminium ducting hose
- Ducting hole dimension 180mm
- Product dimension (mm): 895(W) x 416(D) x 505(H)



## UNIQUE FEATURES



### Wave Hello to Your Cooking Pleasure



### Hand Wave Control

A convenient alternative to suspend or stop your hood when inconvenient to touch the screen.



### 1800m<sup>3</sup>/h Strong Suction

Powerful airflow to efficiently remove the most unpleasant odors, steam and grease.



### 3D Circum Ventilation

The detachable convex condensation plate leaves large air inlets for 360-degree extraction, maximizing the efficiency of cooking fume extraction.



### Complete Smoke Removal

The duct out type exhausts cooking fumes outside the house thoroughly and keeps your kitchen air fresh indeed.



### 3-Minutes Super Extraction Power

Our turbo function can provide 3-minutes maximum suction (1800m<sup>3</sup>/h), perfectly suitable for stir frying.



# COOKER HOOD



Steam Cleaning



Gesture Control



2000m<sup>3</sup>/hr



3D Ventilation



Smart Auto Steam Wash



Turbo Function



Gesture Control

Suction Power  
**2000m<sup>3</sup>/hr**

Duct Out  
Only

## MCH-90M80AT

- Auto Steam Wash Cleaning Technology
- 3D Circum Ventilation
- Suction power: 2000m<sup>3</sup>/hr
- Touch control
- Gesture control (Hand wave power On/Off)
- LED Lamp: 2 x 1.5W
- Duct out operation mode
- Easy clean elongated oil cup
- 2 speeds selection with Turbo speed function
- Included aluminium ducting hose
- Ducting hole dimension 180mm
- Product dimension (mm): 895(W) x 494(D) x 609-919(H)



## UNIQUE FEATURES



### 3D Circum Ventilation

The detachable convex condensation plate, leaves large air inlets for 360-degree extraction and better control and direct smoke flow, optimizing its extraction efficiency.



### 2000m<sup>3</sup>/h Strong Suction

Our turbo function can provide 3-minutes maximum suction (2000m<sup>3</sup>/h), perfectly suitable for stir frying, removing the most unpleasant odors, steam and grease.



### Complete Smoke Removal

The duct out type exhausts cooking fumes outside the house thoroughly and keep your kitchen air fresh indeed.



### Easily-clean Designs

#### Black Glass Plate

Easy to wipe grease off.



### More Humanized Details

#### Injury Prevention Designs

494mm width and rounded corner.

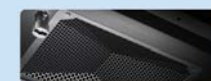

#### Detachable Grease Filter

Easy to detach and clean



#### Legible Control Panel

Intuitive use with a clear picture view.



#### Oil-visible Oil Cup

Clearly indicating oil quantity and reminding you to clean



#### Energy Efficient LED Lights

Ensure a visibility at your stovetop.

# COOKER HOOD



Suction Power  
**1500m<sup>3</sup>/hr**

Duct Out  
Only

**MCH-90B82**

- Suction power: 1500m<sup>3</sup>/hr
- Touch control
- LED lamp: 2 x 1.5W
- Duct out operation mode
- Easy clean elongated oil cup
- 2 speeds selection
- Included aluminium ducting hose
- Ducting hole dimension 170mm
- Product dimension (mm): 895(W) x 480(D) x 510(H)

**5** YEARS WARRANTY  
**MOTOR**

## UNIQUE FEATURES



**Enjoy Cooking Around  
So Fresh Air**



**Complete Smoke Removal**

Exhaust cooking fumes outside the house thoroughly and keep your kitchen air fresh indeed.



**1500m<sup>3</sup>/h Strong Suction**

Powerful airflow to efficiently remove the most unpleasant odors, steam and grease, especially when stir frying.



**Easily-Maintained Durable Parts**

**Stainless steel materials**

The stainless steel body is resistant to high temperature and salt corrosion.

**Easily cleaned designs**

The baffle filter and large oil cup, directly contacting cooking, are designed to be more easily cleaned.



**Intuitive Touch Screen**

Clear and simple touch-function displays are easily understood and intuitively used with your finger.



**Easily-Maintained Durable Parts**

Precisely framed 480mm width of the appliance and rounded corner can effectively prevent you from unexpected injuries.

# COOKER HOOD



Suction Power  
**1500m<sup>3</sup>/hr**

Duct Out  
Only

## MCH-90J15

- Suction power: 1500m<sup>3</sup>/hr
- Touch control
- Gesture control (Hand wave power On/Off)
- LED Lamp: 2 x 1.5W
- Duct out operation mode
- Easy clean elongated oil cup
- 2 speeds selection
- Included aluminium ducting hose
- Ducting hole dimension 180mm
- Product dimension (mm): 900(W) x 347(D) x 525-1365(H)



Suction Power  
**1500m<sup>3</sup>/hr**

Duct Out  
Only

## MCH-90J52

- Suction power: 1500m<sup>3</sup>/hr
- Touch control
- Gesture control (Hand wave power On/Off)
- LED lamp: 2 x 1.5W
- Duct out operation mode
- Easy clean elongated oil cup
- 2 speeds selection
- Included aluminium ducting hose
- Ducting hole dimension 190mm
- Product dimension (mm): 896(W) x 460(D) x 545-1345(H)



Suction Power  
**1200m<sup>3</sup>/hr**

Duct Out /  
Recirculation

## MCH-90TM1

- Suction power : 1200m<sup>3</sup>/hr
- Touch control & digital display
- Air outlet: 150mm
- LED lamp: 2 x 1.5W
- With charcoal filter x 2
- Washable 5-layers grease filters x 3
- Duct out or recirculation operation mode
- 3 speeds selection
- Stainless steel
- Included PVC ducting hose
- Ducting hole dimension 150mm
- Product dimension(mm) : 900(W) x 500(D) x 460(H)



Suction Power  
**1200m<sup>3</sup>/hr**

Duct Out /  
Recirculation

## MCH-90MV1

- Suction power : 1200m<sup>3</sup>/hr
- Push button control
- Air outlet: 150mm
- LED lamp: 2 x 1.5W
- With charcoal filter x 2
- Washable 5-layers grease filters x 2
- Duct out or recirculation operation mode
- 3 speeds selection
- Tempered glass
- Included PVC ducting hose
- Ducting hole dimension 150mm
- Product dimension(mm) : 900(W) x 500(D) x 485(H)



Suction Power  
**1200m<sup>3</sup>/hr**

Duct Out /  
Recirculation

## MCH-90MV3

- Suction power : 1200m<sup>3</sup>/hr
- Push button control
- LEDlamp: 2 x 1.5W
- With charcoal filter x 2
- Washable 5-layers grease filters x 2
- Duct out or recirculation operation mode
- 3 speeds selection
- Stainless steel & tempered glass
- Included PVC ducting hose
- Ducting hole dimension 150mm
- Product dimension(mm) : 900(W) x 500(D) x 485(H)



Suction Power  
**900m<sup>3</sup>/hr**

Duct Out /  
Recirculation

## MCH-76MSS

- 76cm length
- Air outlet size: size: 120mm
- Suction power: 900m<sup>3</sup>/hr
- Stainless steel
- LED lamp
- Push button
- With charcoal filter x 2
- Washable grease filter x 2
- Twin motor, bigger power
- Duct out or recirculating system
- Product dimension(mm) : 757(W) x 500(D) x 140(H)



Suction Power  
**900m<sup>3</sup>/hr**

Duct Out /  
Recirculation

## MCH-90F49SS

- 90cm length
- Air outlet size: 120mm
- Suction power: 900m<sup>3</sup>/hr
- Stainless steel
- LED lamp
- Push button
- With charcoal filter x 2
- Washable grease filter x 3
- Twin motor, bigger power
- Duct out or recirculating system
- Product dimension(mm) : 897(W) x 500(D) x 140(H)



For all models

# BUILT-IN INDUCTION & CERAMIC HOB



## MC-IHD361

- Built-in induction & ceramic hob
- Left zone: 1800W
- Right zone: 1800W
- Touch control
- 9-stages power setting
- Residual heat indicator
- Child lock
- Automatic safety switch off
- Product dimension (mm): 700(W) x 430(D) x 82(H)
- Built-in dimension (mm): 670(W) x 400(D)
- Installed electric power: 3200W
- Voltage: 220-240V

**LIFETIME WARRANTY**

**TEMPERED GLASS**  
(natural crack)





# BUILT-IN GAS HOB



Burner  
**5.8kW**



**MGH-2530GL**

- Preset gas type:LPG
- Burners: 2 x 5.8kW
- 76cm gas hob
- Tempered Glass
- Flame failure safety device
- Production dimension (mm): 760(W) x 420(D)
- Cut out dimension (mm): 645(W) x 340(D)

**LIFETIME WARRANTY** **TEMPERED GLASS**  
(natural crack)

## UNIQUE FEATURES



### Releasing Straight Flame

Evenly distributed fire holes emit powerful straight flames in 5.8kW, target to the bottom of the pan.

### Anti-corrosion

Not afraid of corrosion to serve you longer.

### Deformation Resistance

Strongly keeping their shape for long.

### Leakage Proof Design

Thoughtful design of inner burner cap, keep the flame, also protect your safely.



## Fully Mix Gas & O<sub>2</sub>, Burn To The Limit Of Energy Using

The Bi-Hybrid Combustion System activates the gas twice to fully mix with the O<sub>2</sub>, releasing stronger fire with 65% energy efficiency, which makes your meal ready in less time and energy.



## Even When Stir-frying, Still A Resist-Heatwave Place For You

The thoughtful 1/4 anti-scalding pot ring design allows you to feel comfortable even when the biggest fire is on. At the same time, the heavy material and scientific design also stable your wok, bringing you a friendly cooking experience.

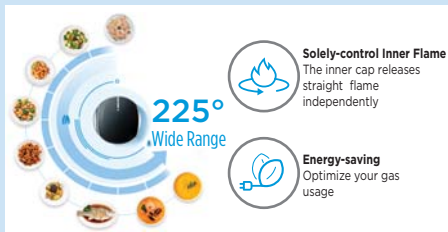

### Solely-control Inner Flame

The inner cap releases straight flame independently

### Energy-saving

Optimize your gas usage

## Various Flame Settings To Customize Your Delicacies

Our hobs serve you for cooking, stir-frying, steaming, braising, and gradual simmering... Precise fire control satisfies your different heating needs and avoid unnecessary gas waste.



## Flexible Installation, Harmoniously Fit In Your Kitchen

Built-in or Free-standing, Decided by you.



## Instantly Ignite The Hob Via Knob, As Well As Your Cooking Inspiration

Just push and turn the knobs, the flame can be triggered instantly, so as your culinary inspiration.



## Temp-Sensing Flame Failure Protection, Guard Your Safety Consciously

The fire went out all of a sudden? A flame failure device will cut off the gas flow to guard your safety. Protection against flame failure.



**Tempered Glass** SG Class

**Glass Fiber Fabric** Extra reinforce protection

**Aluminum Film** Thermal shield

**Sponge Strip** Damping & Waterproof

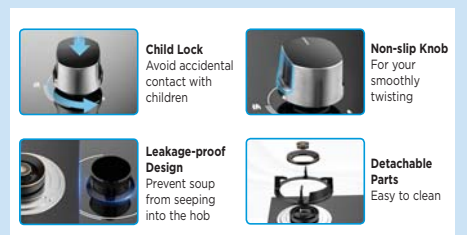

**Child Lock**  
Avoid accidental contact with children

**Non-slip Knob**  
For your smoothly twisting

**Leakage-proof Design**  
Prevent soup from seeping into the hob

**Detachable Parts**  
Easy to clean

## 4-Layers Premium Tempered Glass, Enhance Your Cooking Experience

Strong glass surface made for high quality 4-layers tempered glass, which is resist to HI-temperature and corrosion. Also, gently wipe the stains off, then you will regain a clean and glossy cooktop.

## Humanized Design, Care For Every Detail In Cooking

From the moment you touch Midea hobs, our thoughtful innovative design has been perfecting your culinary journey.

# BUILT-IN GAS HOB



Burner  
5.8kW

**MGH-4360GL** **NEW**

- Preset gas type: LPG
- Burners: 2 x 5.8kW
- 1.5V battery ignition
- 76cm gas hob
- Tempered Glass
- Flame failure safety device
- Product dimension (mm): 760(W)×445(D)
- Cut out dimension (mm): 645-705(W)×340-400(D)

**LIFETIME WARRANTY** **TEMPERED GLASS**  
(natural crack)

## UNIQUE FEATURES

- Releasing Straight Flame**  
Evenly distributed fire holes emit powerful straight flames in 5.8kW, target to the bottom of the pan.
- Anti-corrosion**  
Not afraid of corrosion to serve you longer.
- Deformation Resistance**  
Strongly keeping their shape for long.
- Leakage Proof Design**  
Thoughtful design of inner burner cap, keep the flame, also protect your safety.



**HEATRING CONCENTRATION**

- Premium MAT Enamel
- 720g Heavy Material
- R Angle Claw
- Small milk pot, Large Wok
- Large Range of Applicable Pan Size

### Premium Brass Burner Ignite Your Cooking Passion For Long

Fine burners with surprisingly durable quality, keeping company with you to always bring you food inspiration in your culinary journey.

### Fully Mix Gas & O<sub>2</sub>, Burn To The Limit Of Energy Using

The Bi-Hybrid Combustion System activates the gas twice to fully mix with the O<sub>2</sub>, releasing stronger fire with 65% energy efficiency, which makes your meal ready in less time and energy.

### Steady Your Woks In X Pan Support, Promise Your Safe Cooking

X pan supports strongly hold any kind of pan, large or small, reducing risks of spilling and scalding. Let the woks always stay in their place!

**225° Wide Range**

- Solely-control Inner Flame**  
The inner cap releases straight flame independently
- Energy-saving**  
Optimize your gas usage

**Built-in or Free-standing, Decided by You!**

**Flexibly Cutout, Perfectly Integrate in Your Cooking Bench.**



### Various Flame Settings To Customize Your Delicacies

Our hobs serve you for cooking, stir-frying, steaming, braising, and gradual simmering... Precise fire control satisfies your different heating needs and avoid unnecessary gas waste.

### Flexible Installation, Harmoniously Fit In Your Kitchen

Built-in or Free-standing, Decided by you.

### Instantly Ignite The Hob Via Knob, As Well As Your Cooking Inspiration

Just push and turn the knobs, the flame can be triggered instantly, so as your culinary inspiration.



### Temp-Sensing Flame Failure Protection, Guard Your Safety Consciously

The fire went out all of a sudden? A flame failure device will cut off the gas flow to guard your safety. Protection against flame failure.

- Tempered Glass** SG Class
- Glass Fiber Fabric** Extra reinforce protection
- Aluminum Film** Thermal shield
- Sponge Strip** Damping & Waterproof

### 4-Layers Premium Tempered Glass, Enhance Your Cooking Experience

Strong glass surface made for high quality 4-layers tempered glass, which is resist to HI-temperature and corrosion. Also, gently wipe the stains off, then you will regain a clean and glossy cooktop.

- Child Lock**  
Avoid accidental contact with children
- Leakage-proof Design**  
Prevent soup from seeping into the hob
- Detachable Parts**  
Easy to clean

### Humanized Design, Care For Every Detail In Cooking

From the moment you touch Midea hobs, our thoughtful innovative design has been perfecting your culinary journey.



# BUILT-IN GAS HOB



Burner  
**5.8kW**

**MGH-2280GL** **NEW**

- Preset gas type: LPG
- 1.5V battery ignition
- Tempered Glass
- Flame failure safety device
- Product dimension (mm): 760(W)×445(D)
- Cut out dimension (mm): 645-705(W)×340-400(D)
- Burners: 2 x 5.8kW
- 76cm gas hob

**LIFETIME WARRANTY** **TEMPERED GLASS**  
(natural crack)

## UNIQUE FEATURES



### Flame Focused, Flavor Locked In

Heat Concentration Ring gathers the flame and lets the heat directly target the bottom of the pan, providing focused fire and greater efficiency. The intense heat is ideal for searing seafood and frying other delicious meals.



### Fully Mix Gas & O<sub>2</sub>, Burn To The Limit Of Energy Using

The Bi-Hybrid Combustion System activates the gas twice to fully mix with the O<sub>2</sub>, releasing stronger fire with 65% energy efficiency, which makes your meal ready in less time and energy.



### Steady Your Woks In X Pan Support, Promise Your Safe Cooking

X pan supports strongly hold any kind of pan, large or small, reducing risks of spilling and scalding. Let the woks always stay in their place!

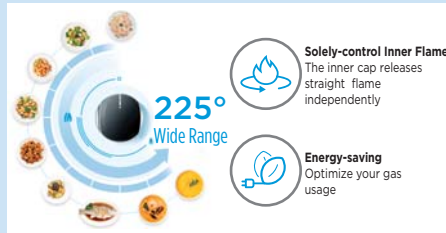

### Various Flame Settings To Customize Your Delicacies

Our hobs serve you for cooking, stir-frying, steaming, braising, and gradual simmering... Precise fire control satisfies your different heating needs and avoid unnecessary gas waste.



### Flexible Installation, Harmoniously Fit In Your Kitchen

Built-in or Free-standing, Decided by you.



### Instantly Ignite The Hob Via Knob, As Well As Your Cooking Inspiration

Just push and turn the knobs, the flame can be triggered instantly, so as your culinary inspiration.



### Temp-Sensing Flame Failure Protection, Guard Your Safety Consciously

The fire went out all of a sudden? A flame failure device will cut off the gas flow to guard your safety. Protection against flame failure.

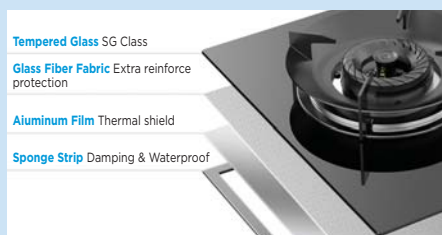

### 4-Layers Premium Tempered Glass, Enhance Your Cooking Experience

Strong glass surface made of high quality 4-layers tempered glass, which is resistant to high temperature and corrosion. Also, gently wipe the stains off, then you will regain a clean and glossy cooktop.

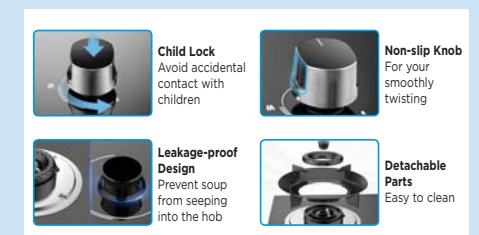

### Humanized Design, Care For Every Detail In Cooking

From the moment you touch Midea hobs, our thoughtful innovative design has been perfecting your culinary journey.

# BUILT-IN GAS HOB



Burner  
5.8kW

MGH-8216SS

NEW

- Preset gas type: LPG
- Burners: 2 x 5.8kW
- 1.5V battery ignition
- 72cm gas hob
- Stainless Steel
- Flame failure safety device
- Product dimension (mm): 720(W)×420(D)
- Cut out dimension (mm): 645(W)×340(D)

## UNIQUE FEATURES

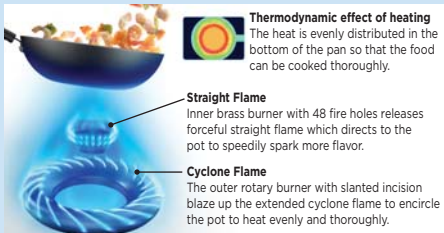

### Dual Flame Enables Even & Quick Cooking

Cyclone Flame matches with the inner straight flame to wrap the base of pans, releasing 5.8kW heating power, perfect for boiling, searing, and frying.



### Fully Mix Gas & O<sub>2</sub>, Burn To The Limit Of Energy Using

The Bi-Hybrid Combustion System activates the gas twice to fully mix with the O<sub>2</sub>, releasing stronger fire with 65% energy efficiency, which makes your meal ready in less time and energy.

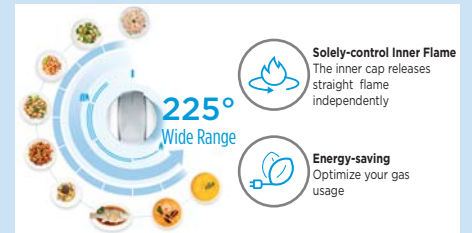

### Various Flame Settings To Customize Your Delicacies

Our hobs serve you for cooking, stir-frying, steaming, braising, and gradual simmering... Precise fire control satisfies your different heating needs and avoid unnecessary gas waste.



### Flexible Installation, Harmoniously Fit In Your Kitchen

Built-in or Free-standing, Decided by you.



### Instantly Ignite The Hob Via Knob, As Well As Your Cooking Inspiration

Just push and turn the knobs, the flame can be triggered instantly, so as your culinary inspiration.



### Temp-Sensing Flame Failure Protection, Guard Your Safety Consciously

The fire went out all of a sudden? A flame failure device will cut off the gas flow to guard your safety. Protection against flame failure.

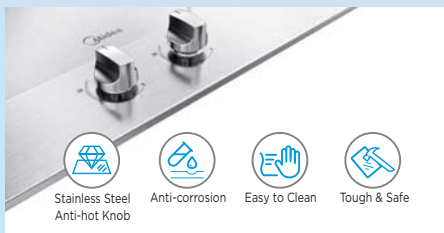

### Stainless Steel Body, Strong Yet Durable

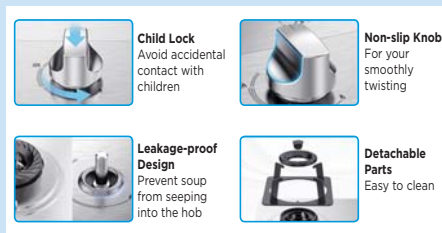

### Humanized Design, Care For Every Detail In Cooking

From the moment you touch Midea hobs, our thoughtful innovative design has been perfecting your culinary journey.





# BUILT-IN GAS HOB



Burner  
**5.0kW**

**MGH-2460GL** **NEW**

- Preset gas type: LPG
- 1.5V battery ignition
- Tempered Glass
- Flame failure safety device
- Product dimension (mm): 760(W)×445(D)
- Cut out dimension (mm): 645(W)×340(D)
- Burners: 2 x 5.0kW
- 76cm gas hob

**LIFETIME WARRANTY**

**TEMPERED GLASS**  
(natural crack)



## Fully Mix Gas & O<sub>2</sub>, Burn To The Limit Of Energy Using

The Bi-Hybrid Combustion System activates the gas twice to fully mix with the O<sub>2</sub>, releasing stronger fire with 65% energy efficiency, which makes your meal ready in less time and energy.

## UNIQUE FEATURES



### Flame Focused, Flavor Locked In

Heat Concentration Ring gathers the flame and lets the heat directly target the bottom of the pan, providing focused fire and greater efficiency. The intense heat is ideal for searing seafood and frying other delicious meals.



### Instantly Ignite The Hob Via Knob, As Well As Your Cooking Inspiration

Just push and turn the knobs, the flame can be triggered instantly, so as your culinary inspiration.



### Temp-Sensing Flame Failure Protection, Guard Your Safety Consciously

The fire went out all of a sudden? A flame failure device will cut off the gas flow to guard your safety.



**Child Lock**  
Avoid accidental contact with children



**Non-slip Knob**  
For your smoothly twisting



**Leakage-proof Design**  
Prevent soup from seeping into the hob



**Detachable Parts**  
Easy to clean

### Humanized Design, Care For Every Detail In Cooking

From the moment you touch Midea hobs, our thoughtful innovative design has been perfecting your culinary journey.



Burner  
**5.0kW**

**MGH-2432GL**

- Preset gas type: LPG
- 76cm gas hob
- Tempered Glass
- Flame failure safety device
- Product dimension (mm): 760(W) x 450(D)
- Cut out dimension (mm): 645(W) x 340(D)
- Burners: 2 x 5kW
- 1.5V battery ignition
- Cast Iron pan support



Burner  
**4.8kW**

**MGH-2411GL**

- Preset gas type: LPG
- 72cm gas hob
- Tempered Glass
- Flame failure safety device
- Optional gas type: Natural gas
- Product dimension (mm): 720(W) x 420(D)
- Cut out dimension (mm): 645(W) x 340(D)
- Burners: 2 x 4.8kW
- 1.5V battery ignition
- Cast Iron pan support



Burner  
**5.0kW**

**MGH-76Q60A**

- Preset gas type: LPG
- 76cm gas hob
- Tempered Glass
- Flame failure safety device
- Product dimension (mm): 760(W) x 445(D)
- Cut out dimension (mm): 645(W) x 340(D)
- Burners: 2 x 5kW
- 1.5V battery ignition
- Cast Iron pan support



**LIFETIME WARRANTY**

**TEMPERED GLASS**  
(natural crack)



**5-levels Flame Control** to suit your cooking preference



**High Efficiency Burners**



**Classy & High Quality Tempered Glass Surface** for easy cleaning



**Child Lock Push Button** for safety purpose



# TABLETOP GLASS STOVE



Burner  
4.7kW

## MGS-T211G

- Portable tabletop glass stove
- Preset gas type: LPG
- Burners: 2 x 4.7kW
- Tempered Glass
- Cast iron burner cap
- High Energy Efficiency (20% less gas consumption)
- 5-claws enamel pan support
- Product Dimension (mm): 720(W) x 350(D) x 140(H)

**LIFETIME WARRANTY** **TEMPERED GLASS**  
(natural crack)

### UNIQUE FEATURES



#### 4.7kW Strong Makes Cooking a Breeze

##### Quick Frying

4.7kW stir-frying heating power with fiercer straight flame speeds cooking process.

##### Fully and Evenly Cooking

Triple ring burner offers more even flame power, promoting food cooked fully and evenly.



#### 20% Less Gas Consumption 10 Years Secure Usage for Longer "Serving you" Time

Our high-standard quality control guarantees 10-years long lifespan, sustaining your cooking enjoyment.



#### Cast Iron Burner Cap

Resistant to wear and high temperature and not easy to deform

#### 60,000 Valve Usages

Our strict quality control guarantees over 60,000 usages of valve, ensuring a reliable long-time use.



#### 20% Less Gas Consumption

The energy efficiency of our gas hob is enhanced to save energy and cost indeed.



#### Easily-clean and Effortless Designs



#### Guaranteed Tempered Glass Plate

6mm thickened tempered glass plate with our lifetime warranty.

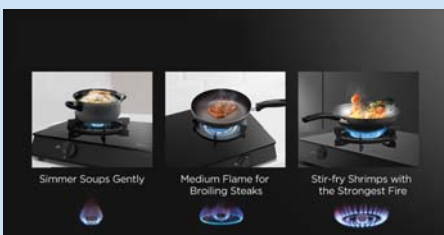

#### Flexible Flame Adjustments, Various Cooking Options



#### Free Installation, Easy Use with Flexibilities

No installation needed to start your culinary pleasure, highly convenient for the situations when you need to relocate it.



#### Caring Child Lock Ultra Safety Protection

Pushing the button and rotating the valve are needed simultaneously, providing effective protection for children from unexpected accidents with fire.

# BUILT-IN OVEN

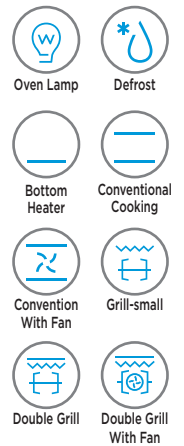

70L

## MBO-D0870

- Built-in 60cm oven
- Digital control with LED display
- Energy rating: A class
- 2 x universal trays & 1 rack
- Product Dimension (mm): 595(W) x 575(D) x 595(H)
- Build-in Dimension (mm): 560(W) x 575(D) x 600(H)
- Capacity size: 70 liters
- 8 functions with rotisserie
- 3 layers removable door
- Maximum power: 3000W

65L

## MBO-M1865

- Built-in 60cm oven
- Mechanic knobs control
- Energy rating: A class
- 2 x universal trays & 1 rack
- Product Dimension (mm): 595(W) x 575(D) x 595(H)
- Build-in Dimension (mm): 560(W) x 575(D) x 600(H)
- Capacity size: 65 liters
- 8 functions with rotisserie
- 2 layers removable door
- Maximum power: 3000W

# BUILT-IN MICROWAVE



25L

## MBM-VE8925

- 2 in 1 Built-in microwave with Grill
- Capacity: 25 liters
- Digital control with LED display
- 10 auto menus
- Multi defrost functions
- Child safety lock
- Microwave power: 900W, Grill power: 1000W
- Product Dimension (mm): 595(W) x 410(D) x 388(H)
- Build-in Dimension (mm): 560(W) x 500(D) x 380(H)



25L

## MBM-1925B

- 2 in 1 Built-in microwave with Grill
- Turnable diameter: 315mm
- 8 Auto cooking menus
- Multi defrost functions
- Heat-resisted glass window
- Stainless steel with black glass door
- Microwave Power: 900W
- Product Dimension (mm): 595(W) x 410(D) x 388(H)
- Build in dimension (mm): 560(W) x 500(D) x 380(H)
- Capacity: 25 litres
- Built in Microwave with grill
- Speedy defrost setting
- Express cooking
- Child safety lock
- Rotary knobs
- Grill power: 1000W

# FREE STANDING DISHWASHER



**WQP12-7635Q** **NEW**

- 14 Place settings
- Stainless steel
- 6 Washing programs
- 70°C high-temp intensive wash
- Half load function
- Child lock
- Product Dimension (mm): 598(W) x 600(D) x 845(H)
- Low noise level
- Flexible rack system
- Auto open drying system
- Extra drying function
- Self-cleaning filter system

**2** years  
**WARRANTY**

## UNIQUE FEATURES



### Anti-bacterial\* Filter Inhibits 99.99% of Bacteria

Our filter, employed anti-bacterial material, constantly inhibits micro-organism buildup inside the tub, ensuring a high level of health protection by inhibiting 99.99% of bacteria.



### Flexible Rack System, Infinite Loading Flexibilities

Allow you stack more categories of tableware, glassware, utensils and even cookware, with superb 14 place setting capacity, making loading and unloading so smooth.



### Half Load

A cost-effective solution for less tableware wash, especially for small families not using many dishes and bowls, with less water and energy consumption.



### Extra Drying

Extra drying function can be added into certain wash cycles, and your dishware with extraordinary drying results.



### Intensive Wash

Efficiently clean the heaviest soiled dishes and cooking utensils, guaranteeing your tableware fairly hygienic to use.



### Delicate Glass Care

Wash glass meticulously and also with softened water by the build-in water softener, to deliver crystal-clear results.



### Effortless Eco-Dishwashing

Dishes are beautifully cleaned with less effort and water consumption.



### Auto Open Drying

At the end of washing cycles, the door of dishwasher will open automatically and leave a gap for air exchange, promoting washed items, even plastic dishes to achieve the best drying performance.



### Child Lock

Effectively protect your children from unexpected accidents, like being scalded by hot steam, and prevent dishwasher damages which is due to children's mistakenly operating.



# FREE STANDING DISHWASHER

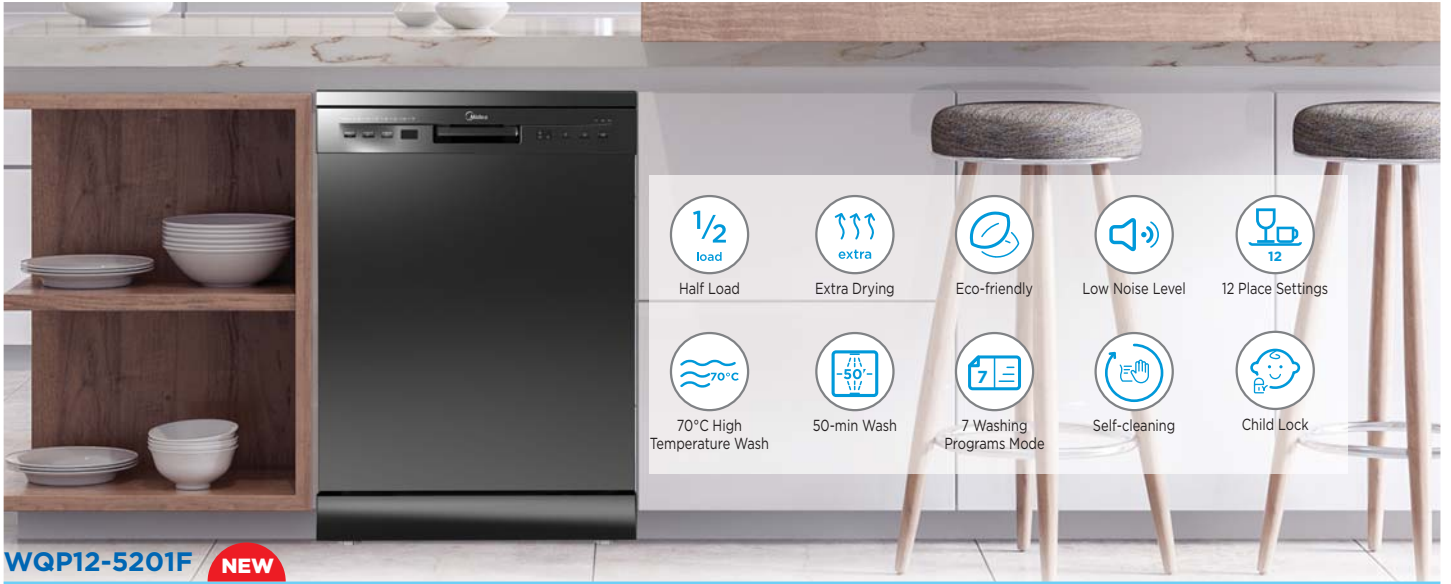

**QWP12-5201F** **NEW**

- 12 Place settings
- Flexible rack system
- Self-cleaning program
- 70°C high-temp intensive wash
- Half load function
- Child lock
- Product Dimension (mm): 598(W) x 600(D) x 845(H)
- Low noise level
- 7 Washing programs
- Residual heat drying system
- Extra drying function
- Self-cleaning filter system

**2** years  
**WARRANTY**

## UNIQUE FEATURES



### 70°C Intensive Wash

Highly effective for cleaning the heaviest soiled dishes and other utensils, and also quite efficient for eliminating 99.99%\* bacteria with high temperature up to 70°C

\* Bacteria elimination rate from Report No: WXw-16-30276 by CTIHEA



### Self-regulated Water Leak Protection System

Our water leak protection system with overflow float switch, regulates itself to detect and cut off any categories of water leakage, not allowing your kitchen to get dirty.



### Flexible Rack System, Infinite Loading Flexibilities

Our flexible rack system, including versatile cutlery basket, foldable flip tines, foldable cup shelf and removable cutlery rack, allows you stack multiple categories of cooking utensils.



### Power-Off Memory, A Perfect Solution For Voltage Instability

Power-off Memory function can remember the unfinished wash cycle when there is a sudden power outage and continue the washing process when power is back on, without need to operate it again.

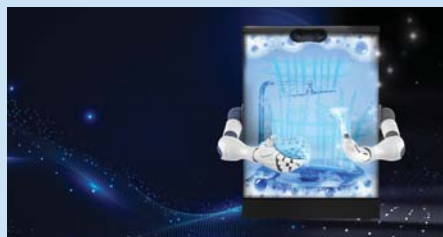

### Self-cleaning for Easy Maintenance

Self-cleaning, 50-min high temperature (70°C) wash cycle for dishwasher itself, can consistently keep your dishwasher fresh and hygienic.



### Anti-bacterial\* Filter Inhibits 99.99% of Bacteria

4Our filter, employed anti-bacterial material, constantly inhibits micro-organism buildup inside the tub, ensuring a high level of health protection by inhibiting 99.99% of bacteria.



### Extra Drying Option

Extra drying can be added into certain wash cycles (Intensive, ECO, Glass and 90 min), and your dishware and even plastic dishes, with extra ordinary drying results.



### Half Load Option

A convenient and cost-effective solution for less tableware wash, especially for small families not using many dishes and bowls, with less water and energy consumption.



### Child Lock Protection

Hold the F and 1/2 buttons for 3 seconds to lock or unlock the control panel, to effectively protect your children from unexpected accidents, like scalding by hot steam, and prevent dishwasher damages due to child's mistakenly operating.

# TABLE TOP DISHWASHER



**WQP6-3607** **NEW**

- 6 Place settings
- Easy installation
- 6 Washing programs
- 70°C high-temp intensive wash
- Product Dimension (mm): 550(W) x 524(D) x 595(H)
- Low noise level
- Flexible rack system
- Residual heat drying system
- Self-cleaning filter system

**2** years  
**WARRANTY**

## UNIQUE FEATURES

### Compact Body, Easy Installation

Small enough to fit anywhere in your room and they always look great.



### Compact Body, Easy Installation

Small enough to fit anywhere in your room and they always look great.



### Intuitive Control with Legible Panel

Simple four-button setting and clear program indicators make your operation so smooth.



### Flexible Rack System, Maximum Loading Possibilities

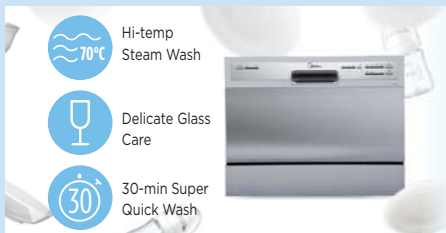

### Personalize Your Uncleaned Items

Reliable cleaning is on your demand.



### 70°C High-Temp Intensive Wash

Efficiently clean the heaviest soiled dishware and glassware, make them fairly hygienic to use, especially for families with babies.



### 30-min Super Quick Wash

Never need to worry running out of tableware when holding a multi-round party.



### Delicate Glass Care

Wash glass meticulously and also with softened water by the build-in water softener, to deliver crystal-clear results.



### Off-peak Wash

Preset your delayed timer to start dishwashing automatically at night to save your electricity cost when you are sleeping.



### Self-cleaning Filter System

Save your effort of cleaning by flushing major food residues.

# INSTANT WATER HEATER

## EU3 SERIES (WITH DC PUMP)

## EU3 SERIES (WITH DC PUMP)



Ag+  
Ag+  
**Ag+ Antibacterial**

Power  
**3800W**

**MWH-38EU3-RS-GR**

- DC Pump
- Rain Showerhead
- 5 Versatile Shower Modes
- Digital Display
- Color : Grey



Ag+  
Ag+  
**Ag+ Antibacterial**

Power  
**3800W**

**MWH-38EU3-GR**

- DC Pump
- Digital Display
- 3 Versatile Shower Modes
- Colour: Grey



Ag+  
Ag+  
**Ag+ Antibacterial**

Power  
**3800W**

**MWH-38U3-SL**

- DC Pump
- 3 Versatile Shower Modes
- Colour: White

### SET YOUR PREFERRED TEMPERATURE PRECISELY



Smart Control System with LED display for precise temperature setting.



**DIGITAL DISPLAY**

### GENERAL FEATURE:



Ag+ Antibacterial



Grounding Fault Indicator



Japan JST Connector



Overheat Protection



Low Noise DC Pump



Nylon Glass Fibre



Whirl Flow Tech



Anti Dry-heating Protection



Built-in Auto Flow Sensor



Copper Heating Element



Built-in ELCB



Splash-proof IP25 Standard



3.8kW Power Output



Double Relay



Earthing Protection



Precise Thermal Cut-out

### 5 VERSATILE SHOWER MODES



**Standard**  
Full body sprays relieve muscle tension to rejuvenate and invigorate your body.



**Soothe**



**Combo**



**Massage**  
Uses pulsating jets of water to relieve stress



**Jumbo**  
Concentrates a stream of water into a small area for fast rinsing

**USD 20 million**  
Insurance Coverage by **Allianz**

Approved by:

Suruhanjaya Tenaga



For all Instant Water Heater:

### WARRANTY

**1** year Parts & Labour | **6** years DC Water Pump | **6** years Heating Element

\* Worldwide warranty for all water heater product



# INSTANT WATER HEATER

## P SERIES (WITH DC PUMP)



Power  
3800W

### MWH-38P3-RS (BLACK)

- Stepless Electronic Pump Control
- Rain Showerhead
- 5 Versatile Shower Modes
- Auto Test
- DC pump

Power  
3800W

### MWH-38P3 (BLACK)

- Stepless Electronic Pump Control
- 5 Versatile Shower Modes
- Auto Test
- DC pump

Power  
3800W

### MWH-38P3 (WHITE)

- Stepless Electronic Pump Control
- 3 Versatile Shower Modes
- Auto Test
- DC pump

## Q SERIES (NO PUMP)

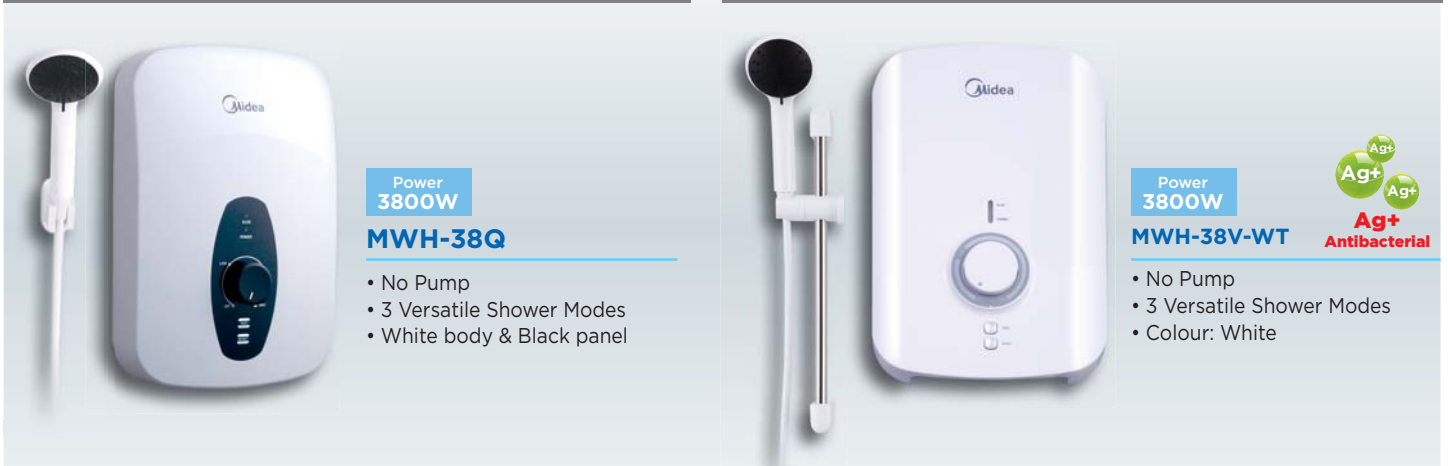

Power  
3800W

### MWH-38Q

- No Pump
- 3 Versatile Shower Modes
- White body & Black panel

Power  
3800W

### MWH-38V-WT

- No Pump
- 3 Versatile Shower Modes
- Colour: White



### GENERAL FEATURE:



**USD 20 million**  
Insurance Coverage by **Allianz**

Approved by:



### 3 VERSATILE SHOWER MODES



#### Standard

Full body sprays relieve muscle tension to rejuvenate and invigorate your body.



#### Jumbo

Concentrates a stream of water into a small area for fast rinsing



#### Massage

Uses pulsating jets of water to relieve stress

For all Instant Water Heater:

### WARRANTY

**1** year Parts & Labour | **6** years DC Water Pump | **6** years Heating Element

\* Worldwide warranty for all water heater product

# STORAGE WATER HEATER



Horizontal Or Vertical Mount



Sapphire Enamel Heating Element

Incoloy 800 or 840 stainless steel with enamel tech, maintains best performance under high temperature & pressure conditions.

Power  
**1500W**  
**MSH-30VH**

• Capacity: 30L

Power  
**1500W**  
**MSH-50VH**

• Capacity: 50L



Electric Water Heater with Electricity Shock Proof

Built-in electricity guard technology supports the safeguard for the excessive voltage to be neutralized in the water heater. It's a reliable shield that protects you from electrical shocks unlike other conventional water heater. Basically, it is never been safer for bathing.



1. Sapphire Enamel Inner Container
2. Overall Polyurethane Foam
3. 27% thicker Magnesium anoda
4. Sapphire Enamel Heating Element
5. Stepless Control

**WARRANTY**

**2** years Full Warranty | **4** years Heating Element | **7** years Tank Leaking



Waterproof Grade: IPX4



Thicker Magnesium Anode



Anti Dry-Heating Protection



Anti Over-Pressure Protection



Sapphire Enamel Tank



Thermometer



Overheat Protection



Overall Polyurethane Foam



Earthing Protection

## STORAGE WATER HEATER SPECIFICATIONS

	MSH-30VH	MSH-50VH	MSH-80VH	MSH-100VH
Capacity (L)	30	50	80	100
Rated Power (W)	1500	1500	1500	1500
Voltage (V~)	220/230	220/230	220/230	220/230
Frequency (Hz)	50/60	50/60	50/60	50/60
Current (A)	6.81/6.52	6.81/6.52	6.81/6.52	6.81/6.52
Temperature Range (°C)	30-75	30-75	30-75	30-75
Maximum Working Pressure (MPa)	0.75	0.75	0.75	0.75
Max Temperature (°C)	101	101	101	101
Material Thickness (mm)	2	1.8	2	2
Outer Cabinet Material	SPCC	SPCC	SPCC	SPCC
Inner Tank	Enamel tank	Enamel tank	Enamel tank	Enamel tank
Average Thickness Of Insulation (mm)	20	22.5	20	20
Magnesium Anode Size (mm)	Φ22x234	Φ22x234	Φ22x296	Φ22x296
Type of Heating Element	Copper/Enamel/SUS316L	Copper/Enamel/SUS316L	Copper/Enamel/SUS316L	Copper/Enamel/SUS316L
Type Of Mounting	VERTICAL/HORIZONTAL	VERTICAL/HORIZONTAL	VERTICAL/HORIZONTAL	VERTICAL/HORIZONTAL
Net Weight (kg)	14.79	18.3	26.31	28.5
Gross Weight (kg)	16.49	20.63	29.4	30.5
Dimensions (WxD) (mm)	340x593	385x711	385x1030	450x895
Carton size (WxDxH) (mm)	418x388x670	458x434x793	458x434x1125	528x498x977

# KITCHEN APPLIANCES DIMENSION

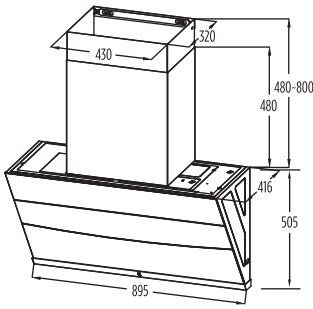

**MCH-90B68AT**

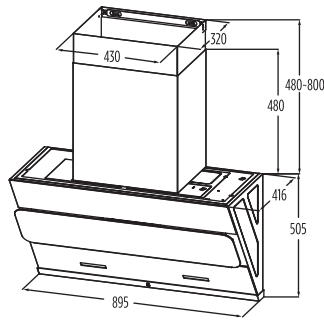

**MCH-90B65**

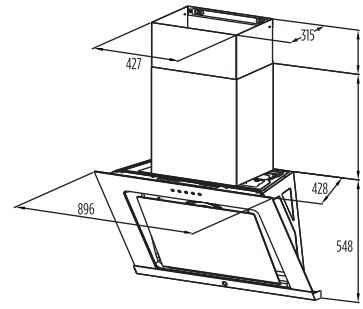

**MCH-90TR1**

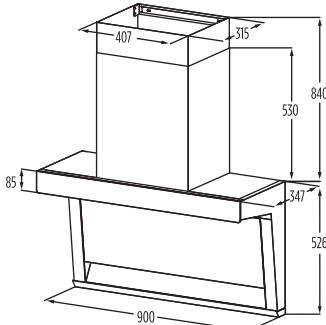

**MCH-90J15**

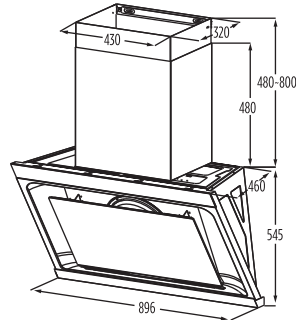

**MCH-90J52**

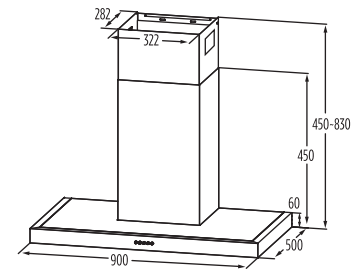

**MCH-90TM1**

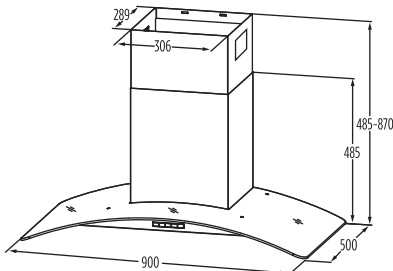

**MCH-90MV1 / MCH-90MV3**

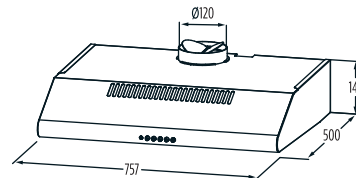

**MCH-76MSS**

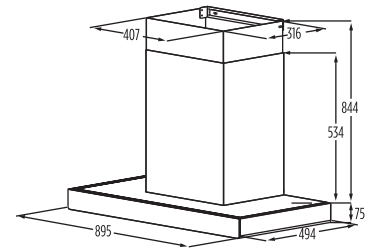

**MCH-90M80AT**

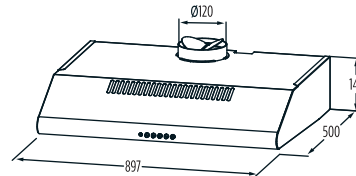

**MCH-90F49SS**

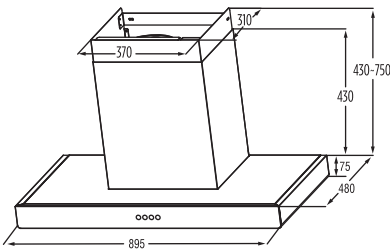

**MCH-90B82**

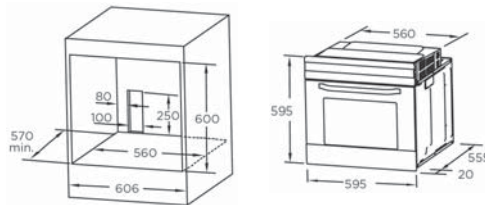

**MBO-D0870 / MBO-M1865 / MBO-3658M / MBO-3709M**

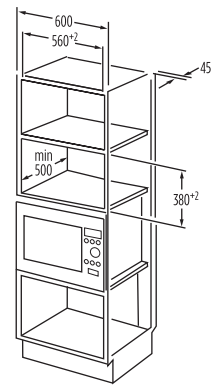

**MBM-1925B / MBM-VE8925 OAT**

Dealer's Stamp:

Available at lazada & Shopee



shopee.com.my/midea.os



lazada.com.my/shop/  
midea-official-store



midea\_malaysia



Midea Malaysia



my.midea.com

\*Price, models & gifts are subject to change without prior notice. Valid only while stocks last. Pictures are for illustration purposes only. This promotion is not inclusive of duty-free products, project sales, accessories, usage & installation charges.

Sole Distributor :

**Midea Scott & English Electronics Sdn Bhd** (194517-X)

No. 16, Jalan Chan Sow Lin, 55200 Kuala Lumpur Tel: 03-9221 1033 Fax: 03-9221 7204 / 03-9221 1434 / 03-9221 3509

- **PENANG** No. 35, Jalan Perniagaan Gemilang 1, Pusat Perniagaan Gemilang, 14000 Bukit Mertajam, Pulau Pinang. Tel: 04-548 3938 Fax: 04-548 9698 • **JOHOR** No. 25, Jalan Seri Impian 1, Taman Impian Emas, 81300 Skudai, Johor. Tel: 07-562 4898 Fax: 07-557 7898
- **PERAK** No. 38, Persiaran Perindustrian Pengkalan 10, Kawasan Perindustrian Pengkalan, 31500 Lahat, Perak. Tel: 05-323 2529 Fax: 05-323 2529 • **PAHANG** No. 258, Ground Floor, Jalan Air Putih, Taman Air Putih Mewah, 25350 Kuantan, Pahang Darul Makmur. Tel: 09-560 6668 Fax: 09-09-560 5050
- **MALACCA** No. 385-L, Taman Peringgil Jaya, 75400 Peringgil, Melaka. Tel: 06-292 1940 Fax: 06-286 7107 • **KOTA BHARU** PT 1436, Ground Floor, Taman Koperatif, Tanjung Chat, 15300 Kota Bharu, Kelantan. Tel/Fax: 09-743 1202
- **SABAH** Inanam Suria Commercial Centre, Lot B, Unit 0-9, Unit 1-9, Ground Floor and First Floor, 88450, Kota Kinabalu, Sabah. Tel: 088-421 428 Fax: 088-431 427 • **SARAWAK** 1st Floor, Lot 8517, Stutong Commercial Centre, Jalan Stutong, 93350 Kuching, Sarawak. Tel: 082-363 167 Fax: 082-366 167